

Three holes tapped for
0-80 (or smaller)
screws counterbored to
level of indentation

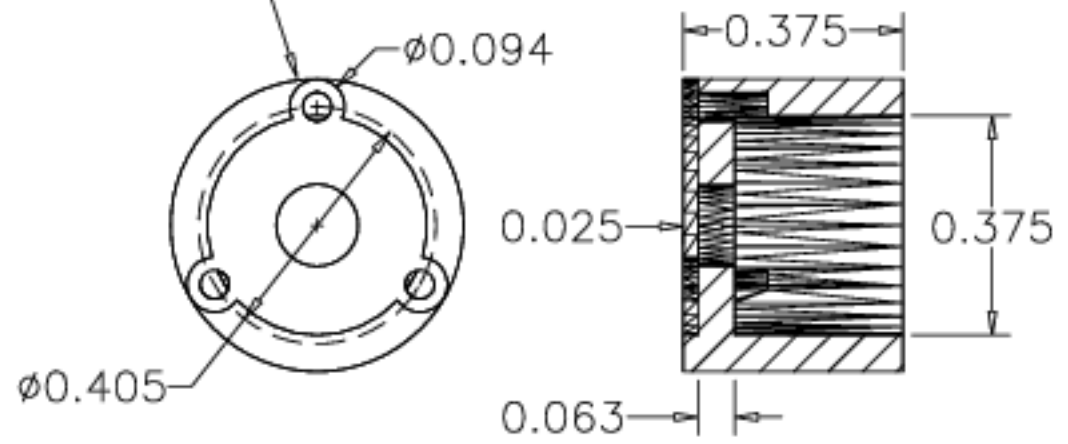

Modification of slit holder (part
21-021) to include three screws for
holding the slit in place.